

**PLEASE CHECK WWW.MOLEX.COM FOR LATEST PART INFORMATION**

**Part Number:** [0350211160](#)  
**Status:** **Active**  
**Description:** 2.00mm (.079") Board-In Terminal for 22-30 AWG, Right Angle, Phosphor Bronze, Lead-free, Post-Tin Plating

**Documents:**

[3D Model](#) [Product Specification PS-35021-001 \(PDF\)](#)  
[Drawing \(PDF\)](#) [RoHS Certificate of Compliance \(PDF\)](#)

**General**

Product Family	Crimp Terminals
Series	<a href="#">35021</a>
Comments	Right Angle, Use with Housing 35023
Crimp Quality Equipment	Yes
Product Name	Board-In

**Physical**

Gender	Male
Material - Metal	Phosphor Bronze
Material - Plating Mating	Tin
Material - Plating Termination	Tin
Packaging Type	Reel
Plating min: Mating (µin)	40
Plating min: Mating (µm)	1
Plating min: Termination (µin)	40
Plating min: Termination (µm)	1
Termination Interface: Style	Crimp or Compression
Wire Insulation Diameter	1.90mm (.075") max.
Wire Size AWG	22, 24, 26, 28, 30
Wire Size mm <sup>2</sup>	N/A

**Material Info**

**Reference - Drawing Numbers**

Product Specification	PS-35021-001
Sales Drawing	SD-35021-002

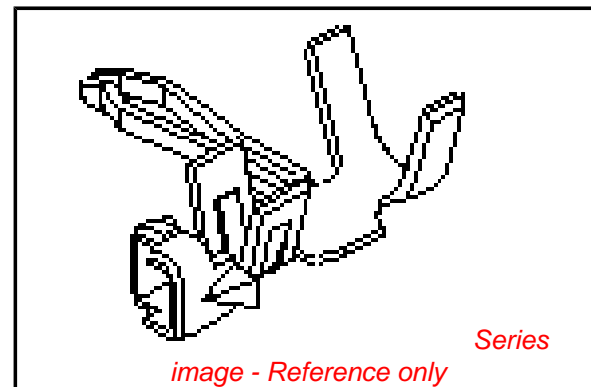

**EU RoHS**

**ELV and RoHS Compliant**  
**REACH SVHC**  
**Contains SVHC: No**  
**Halogen-Free Status**

**China RoHS**



**Need more information on product environmental compliance?**

Email [productcompliance@molex.com](mailto:productcompliance@molex.com)  
 For a multiple part number RoHS Certificate of Compliance, [click here](#)

Please visit the [Contact Us](#) section for any non-product compliance questions.

**Search Parts in this Series**

[35021Series](#)

**Use With**

[35023](#)

**Application Tooling | FAQ**

*Tooling specifications and manuals are found by selecting the products below. Crimp Height Specifications are then contained in the Application Tooling Specification document.*

**Global**

Description	Product #
HAND CRIMP TOOL	<a href="#">0638116900</a>
T2 Terminator	<a href="#">0638532100</a>
Tooling Die	
FineAdjust™	<a href="#">0638632100</a>
Applicator	

DWG. IO.  
SD-35021-002

SIMILAR ITEM

PROJECT NO.

C

B

DO NOT SCALE DRAWING  
DIMENSION IN METRIC

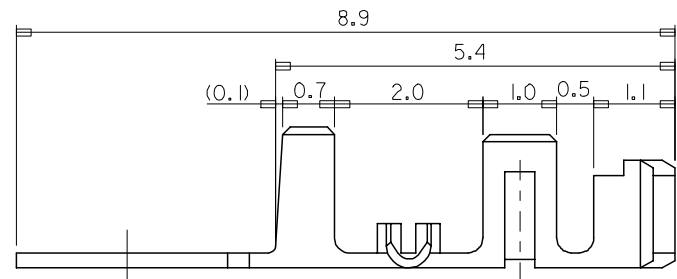
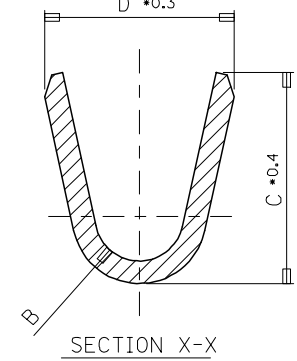
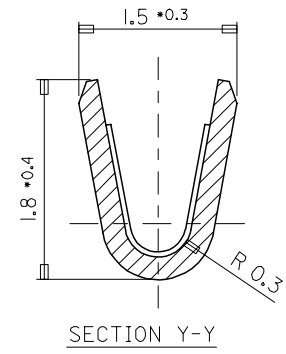
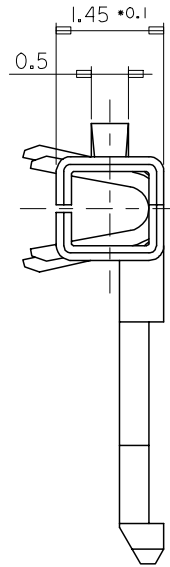
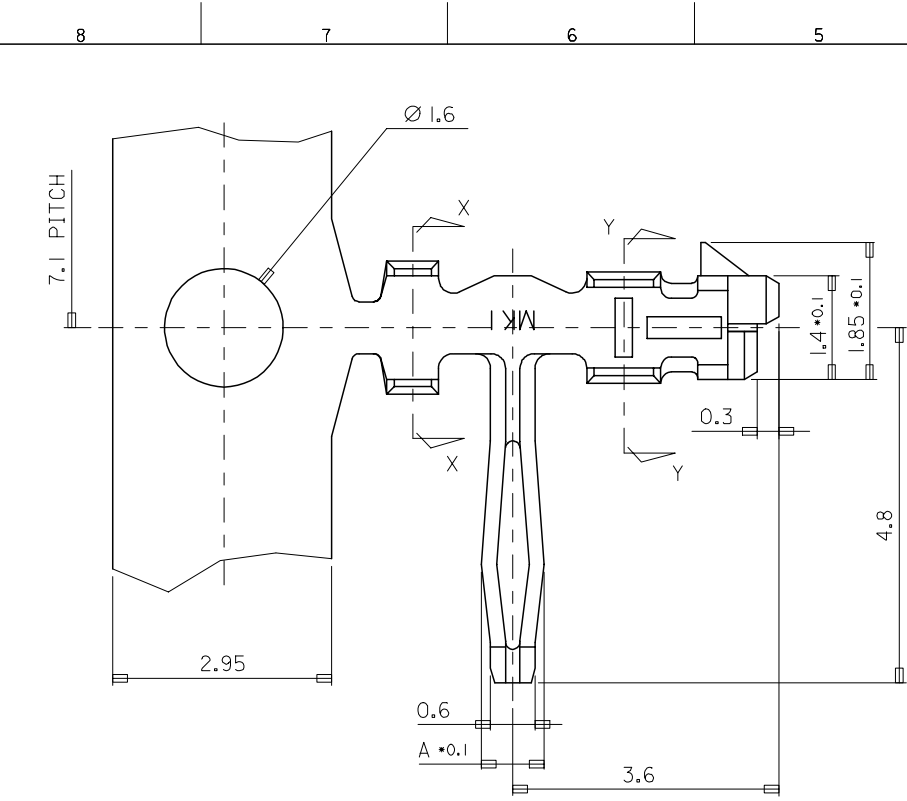

**NOTES:**

- 1. MATERIAL
  - 1) BRASS (CDA 260)
  - 2) PHOSPHOR BRONZE (CDA 510)
- 2. FINISH
  - TIN(Sn) THICKNESS = 3.0 MICROMETER MINIMUM
  - NICKEL(Ni) UNDERPLATE THICKNESS=1~3 MICROMETER
- 3. USED HOUSING : 35022-00\*\*/35023-00\*\*/68418-\*\*\*00
- 4. THIS PRODUCT IS LEAD FREE OF 35021-\*\*\*10

POST-PLATED	PHOS. BRON.	AWG #24-#30 (INS. DIA: Ø 1.5 MAX.)	1.8	1.9	R0.4	0.85	350211360	35021-1360
POST-PLATED	PHOS. BRON.	AWG #22-#30 (INS. DIA: Ø 1.9 MAX.)	2.5	2.5	R0.7	1.05	350211160	35021-1160
PLATING	MATERIAL	WIRE RANGE	D	C	B	A	MAT'L NO.	ENG NO.

REVISED EC NO. K0R2007-0069 DRWN: H.JEONG 2006/12/22 CHK: K.S.KIM 2006/12/22 APPR: Y.SOOKIM 2006/12/22	QUALITY SYMBOLS MAJOR = CRITICAL =	GENERAL TOLERANCES: (UNLESS SPECIFIED)		SCALE 15-1	DESIGN UNITS <input checked="" type="checkbox"/> mm <input type="checkbox"/> INCH	THIRD ANGLE PROJECTION	DIMENSIONS: <input type="checkbox"/> mm <input type="checkbox"/> INCH <input type="checkbox"/> mm <input checked="" type="checkbox"/> ONLY		SHT   REV	
		4 PLACES ±0.   ±.	3 PLACES ±0.   ±.	2 PLACES ±0.   ±.	1 PLACE ±0.3   ±.	DRAWN BY & DATE HSSHIN		CHECKED BY & DATE JKOH		TITLE: R/A B-IN TERMINAL -LEAD FREE-
DESCRIPTION	REV	ANGULAR: ± 1 °		APPROVED BY & DATE CWLEE		MATERIAL NO. SEE TABLE		DRAWING NO. SD-35021-002		
		DRAFT WHERE APPLICABLE MUST REMAIN WITHIN DIMENSIONS		CAD FILENAME SD35021.DGN		THIS DRAWING CONTAINS INFORMATION THAT IS PROPRIETARY TO MOLEX INCORPORATED AND SHOULD NOT BE USED WITHOUT WRITTEN PERMISSION.		SIZE B		

LEAD FREE

MX-A3