

PLEASE CHECK WWW.MOLEX.COM FOR LATEST PART INFORMATION

Part Number: [0008500105](#)
Status: **Active**
Overview: [kk](#)
Description: 3.96mm (.156") Pitch KK® Crimp Terminal 2478, 18-24 AWG, Reel, Brass Tin (Sn)

Documents:

[Drawing \(PDF\)](#) [RoHS Certificate of Compliance \(PDF\)](#)
[Product Specification PS-08-50 \(PDF\)](#)

General

Product Family	Crimp Terminals
Series	2478
Crimp Quality Equipment	Yes
Overview	kk
Product Name	KK®

Physical

Gender	Female
Material - Metal	Brass
Material - Plating Mating	Tin
Material - Plating Termination	Tin
Packaging Type	Reel
Plating min: Mating (µin)	100
Plating min: Mating (µm)	2.50
Plating min: Termination (µin)	100
Plating min: Termination (µm)	2.50
Termination Interface: Style	Crimp or Compression
Wire Insulation Diameter	2.79mm (.110") max.
Wire Size AWG	18, 20, 22, 24
Wire Size mm²	N/A

Material Info

Old Part Number	2478-1(P909)
-----------------	--------------

Reference - Drawing Numbers

Product Specification	PS-08-50
Sales Drawing	SD-2478

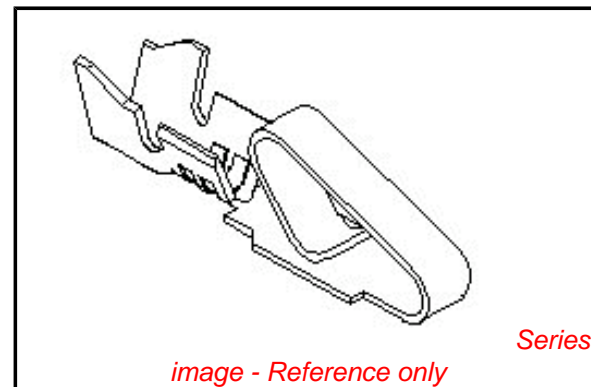

image - Reference only

EU RoHS

**ELV and RoHS
Compliant**
**REACH SVHC
Contains SVHC: No**
**Halogen-Free
Status**

China RoHS



**Need more information on product
environmental compliance?**

Email productcompliance@molex.com
 For a multiple part number RoHS Certificate of Compliance, [click here](#)

Please visit the [Contact Us](#) section for any non-product compliance questions.

Search Parts in this Series

[2478Series](#)

Use With

[2574](#) , [2139](#) , [41695](#) , [3069](#) , [6422](#) , [5265](#) , [5239](#)

Application Tooling | FAQ

Tooling specifications and manuals are found by selecting the products below. Crimp Height Specifications are then contained in the Application Tooling Specification document.

Global

Description	Product #
Extraction Tool	0011030016
Terminator Die	0011402096
FineAdjust™	0639007200
Applicator for KK® and Trifurcon™ Crimp Terminal	
FineAdjust for Mini-Fit Jr.™ Crimp Terminals	0639007300

Special
cut-off tab width
for 2478 Series
terminals using the
7241 Series IDT
housing only. 2478
Series terminals
are not rated for
USCAR21 compliancy.

Japan

Description	Product #
--------------------	------------------

Hand Extraction Tool	<u>0011260059</u>
----------------------	-------------------

Hand Extraction Tool	<u>0570926000</u>
----------------------	-------------------

This document was generated on 06/07/2010

PLEASE CHECK WWW.MOLEX.COM FOR LATEST PART INFORMATION

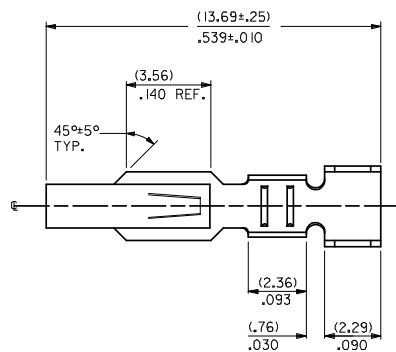
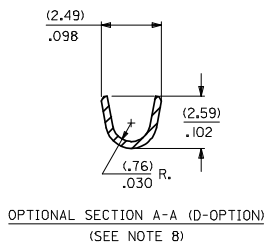
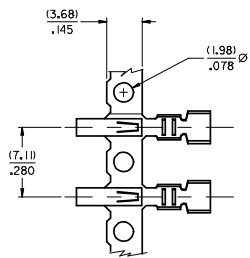

2478- * - * - *

MATERIAL CODE
(.27)/.0106 THK
1=BRASS
3=PHOS BRONZE

OPTION CODE
BLANK=AS SHOWN
C=CAT EAR OPTION
D=OPTIONAL CONDUCTOR CRIMP (FOR IRELAND) (SEE OPT. SECTION A-A) WITHOUT CAT EARS
E=LOW INSERTION FORCE OPTION

WINDING SPEC.
A=PER ES-339-A
BLANK=PER ES-339-B
L=LOOSE

FINISH: PER SDES-88
(P909) *OVERALL HOT TIN DIP: 2.54 MICROMETERS MIN.
(550) SELECT GOLD: 0.38 MICROMETERS MIN.
OVERALL GOLD FLASH: 0.05 MICROMETERS MIN.
OVERALL NICKEL UNDERPLATE: 0.76 MICROMETERS MIN.
(555) SELECT GOLD: 0.38 MICROMETERS MIN.
OVERALL NICKEL UNDERPLATE: 0.76 MICROMETERS MIN.

*THE PRIMARY SHIPPING CARTON WILL BE LABELED "COMPLIANT TO RoHS DIRECTIVE 2002/95/EC AND ELV ANNEX II OF DIRECTIVE 2000/53/EC". CARTONS WITHOUT THIS LABEL MAY CONTAIN PRODUCT WITH TIN/LEAD PLATING.

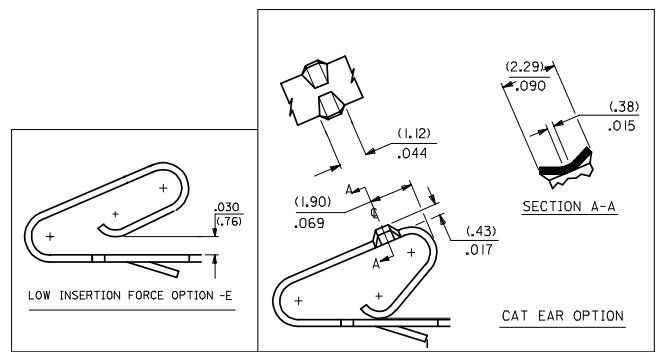
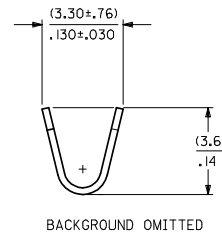
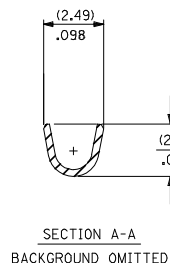
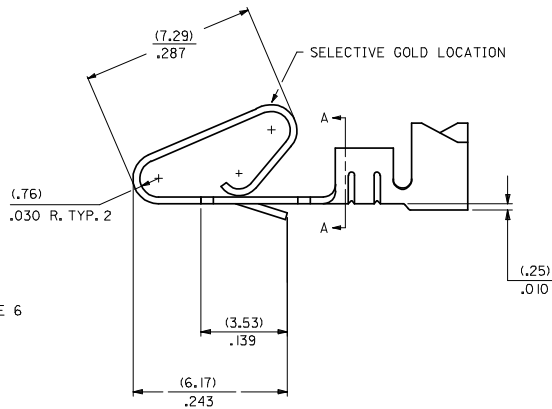
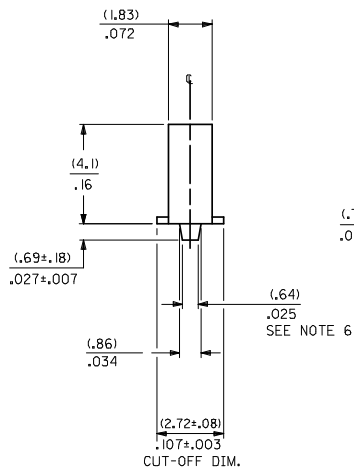

- NOTES:
- CRIMP ACCEPTS 18 TO 24 GA. WIRE WITH (2.79)/.110 MAX. INSUL. DIA.; WHEN USED WITH 2574 CONNECTOR, (2.54)/.100 MAX. INSUL. DIA. WHEN USED WITH 2139 CONNECTOR; HOUSING 41695 IS RECOMMENDED FOR OVER (2.54)/.100 DIA. INSULATION. CRIMP ACCEPTS (3.00)/.118 MAX. INSUL. DIA. WITH SPECIAL TOOLING.
 - DIMENSIONS GIVEN ACROSS CENTERLINES ARE SYMMETRICAL ABOUT THOSE CENTERLINES WITHIN HALF THE TOTAL TOLERANCE.
 -
 -
 -
 - (.86±.05)/.034±.002 IS AN OPTIONAL DESIGN.
 - THIS PART CONFORMS TO PRODUCT SPEC. 08-50.
 - CONDUCTOR CRIMP FOR 16 AWG. WIRE WITH .110 MAX. INSULATION DIA.

CHANGE TO ME10 EC NO: UCP2005-0902 DRAWN BY: DRWNADRAIROL 2004/11/16 CHKD BY: CHKDSAMIEC 2006/03/28 APPROVED BY: APPRPHARMACULUS 2004/11/02/28	QUALITY SYMBOLS ▽=0 ▽=0	GENERAL TOLERANCES (UNLESS SPECIFIED)		DIMENSION STYLE IN/MM		SCALE	DESIGN UNITS INCH	THIRD ANGLE PROJECTION
		4 PLACES ±.005 ±.005	3 PLACES ±.005 ±.010	2 PLACES ±.025 ±.014	1 PLACE ±.036 ±.014	ANGULAR ±1/2°	DRAWN BY: SAMIEC 06/03/86	DATE: 06/03/86
DRAFT WHERE APPLICABLE MUST REMAIN WITHIN DIMENSIONS		MATERIAL NO. SEE CHART		DOCUMENT NO. SD-2478		MOLEX INCORPORATED		
SIZE D		THIS DRAWING CONTAINS INFORMATION THAT IS PROPRIETARY TO MOLEX INCORPORATED AND SHOULD NOT BE USED WITHOUT WRITTEN PERMISSION						

2478-1-(***)*			2478-3-(***)*			2478-IC-(***)*			2478-3C-(***)*			2478-ID-(***)*			2478-3E-(***)*		
PART NO.	ENG. NO.		PART NO.	ENG. NO.		PART NO.	ENG. NO.		PART NO.	ENG. NO.		PART NO.	ENG. NO.		PART NO.	ENG. NO.	
08-50-0105	2478-1-(P909)		08-52-0071	2478-3-(P909)		08-50-0014	2478-IC-(P909)		08-52-0044	2478-3C-(P909)		08-50-0055	2478-ID-(P909)			2478-3E-(P909)	
08-50-0106	2478-1-(P909)L		08-52-0072	2478-3-(P909)L		08-50-0045	2478-IC-(P909)L		08-52-0045	2478-3C-(P909)L		08-50-0056	2478-ID-(P909)L			2478-3E-(P909)L	
08-56-0105	2478-1-(550)		08-65-0114	2478-3-(555)		08-50-0047	2478-IC-(P102)		08-52-0023	2478-3C-(102)					2478-3E-(555)		
08-56-0106	2478-1-(550)L		08-65-0115	2478-3-(555)L		08-50-0046	2478-IC-(P102)L		08-52-0024	2478-3C-(102)L					2478-3E-(555)L		
08-55-0103	2478-1-(555)		08-52-0073	2478-3-(P102)		08-50-0091	2478-IC-(102)		08-52-0027	2478-3C-(122)					2478-3E-(550)		
08-55-0104	2478-1-(555)L		08-52-0074	2478-3-(P102)L		08-50-0093	2478-IC-(102)L		08-52-0027	2478-3C-(122)L					2478-3E-(550)L		
08-50-0146	2478-1-(109)		08-52-0811	2478-3-(102)					08-52-0047	2478-3C-(P102)							
08-50-0147	2478-1-(109)L		08-52-0812	2478-3-(102)L					08-52-0046	2478-3C-(P102)							
08-50-0119	2478-1-(122)		08-50-0281	2478-3-(122)													
08-50-0120	2478-1-(122)L																
08-50-0271	2478-1-(P909)A		08-58-0121	2478-3-(550)													
	2478-1-(507)		08-58-0122	2478-3-(550)L													
	2478-1-(507)L		08-58-0103	2478-3-(591)													
08-56-0153	2478-1-(507)		08-58-0104	2478-3-(591)L													
08-56-0154	2478-1-(506)		08-58-0114	2478-3-(558)													
	2478-1-(506)L		08-58-0115	2478-3-(558)L													
08-50-0015	2478-1-(102)																
08-50-0016	2478-1-(102)L																
08-52-0114	2478-1-(P909)																
08-52-0115	2478-1-(P909)L																
	2478-1-(132)																
	2478-1-(132)L																
08-50-0001	2478-1-(P224)																
08-50-0006	2478-1-(P224)L																
08-50-0063	2478-1-(224)																
08-50-0064	2478-1-(224)L																
08-55-0133	2478-1-(561)																
08-55-0134	2478-1-(561)L																
08-50-0073	2478-1-(P102)																
08-50-0074	2478-1-(P102)L																

SEE SHEET I	SEE SHEET I	DIMENSIONS SHOWN ARE IN INCH UNLESS OTHERWISE SPECIFIED DIMENSIONS ARE IN MILLIMETERS 1 INCH = 25.4 MM 1 MILLIMETER = 0.03937 INCH 1 INCH = 25.4 MM 1 MILLIMETER = 0.03937 INCH DIMENSIONS ARE IN MILLIMETERS UNLESS OTHERWISE SPECIFIED	DIMENSIONS SHOWN ARE IN INCH UNLESS OTHERWISE SPECIFIED DIMENSIONS ARE IN MILLIMETERS 1 INCH = 25.4 MM 1 MILLIMETER = 0.03937 INCH DIMENSIONS ARE IN MILLIMETERS UNLESS OTHERWISE SPECIFIED	DIMENSIONS SHOWN ARE IN INCH UNLESS OTHERWISE SPECIFIED DIMENSIONS ARE IN MILLIMETERS 1 INCH = 25.4 MM 1 MILLIMETER = 0.03937 INCH DIMENSIONS ARE IN MILLIMETERS UNLESS OTHERWISE SPECIFIED	DIMENSIONS SHOWN ARE IN INCH UNLESS OTHERWISE SPECIFIED DIMENSIONS ARE IN MILLIMETERS 1 INCH = 25.4 MM 1 MILLIMETER = 0.03937 INCH DIMENSIONS ARE IN MILLIMETERS UNLESS OTHERWISE SPECIFIED
SEE SHEET I	SEE SHEET I		SEE SHEET I	SEE SHEET I	SEE SHEET I
SEE SHEET I	SEE SHEET I		SEE SHEET I	SEE SHEET I	SEE SHEET I
SEE SHEET I	SEE SHEET I		SEE SHEET I	SEE SHEET I	SEE SHEET I
SEE SHEET I	SEE SHEET I		SEE SHEET I	SEE SHEET I	SEE SHEET I
SEE SHEET I	SEE SHEET I		SEE SHEET I	SEE SHEET I	SEE SHEET I
SEE SHEET I	V	SEE SHEET I	SEE SHEET I	SEE SHEET I	
LTR. REVISIONS	LTR. REVISIONS	DATE: 06/12/86	SCALE: 1:1	CRIMP TERMINAL .156 18/24 AWG WIRE MOLEX INCORPORATED 1325 LEXINGTON AVENUE NEW YORK, N.Y. 10017 U.S.A. SHEET NO. 2 DATE 06/12/86 SEE CHARTS SD-2478 THE DRAWING CONTAINS INFORMATION THAT IS PROPRIETARY TO MOLEX INC. AND SHALL BE KEPT STRICTLY CONFIDENTIAL. DRG. NO. KK D	