

# DATA SHEET

## **TJA1040** High speed CAN transceiver

Product specification  
Supersedes data of 2003 Feb 19

2003 Oct 14

## High speed CAN transceiver

## TJA1040

## FEATURES

- Fully compatible with the ISO 11898 standard
- High speed (up to 1 MBaud)
- Very low-current standby mode with remote wake-up capability via the bus
- Very low ElectroMagnetic Emission (EME)
- Differential receiver with high common-mode range for ElectroMagnetic Immunity (EMI)
- Transceiver in unpowered state disengages from the bus (zero load)
- Input levels compatible with 3.3 V and 5 V devices
- Voltage source for stabilizing the recessive bus level if split termination is used (further improvement of EME)
- At least 110 nodes can be connected
- Transmit Data (TXD) dominant time-out function
- Bus pins protected against transients in automotive environments
- Bus pins and pin SPLIT short-circuit proof to battery and ground
- Thermally protected.

## GENERAL DESCRIPTION

The TJA1040 is the interface between the Controller Area Network (CAN) protocol controller and the physical bus. It is primarily intended for high speed applications, up to 1 MBaud, in passenger cars. The device provides differential transmit capability to the bus and differential receive capability to the CAN controller.

The TJA1040 is the next step up from the TJA1050 high speed CAN transceiver. Being pin compatible and offering the same excellent EMC performance, the TJA1040 also features:

- An ideal passive behaviour when supply voltage is off
- A very low-current standby mode with remote wake-up capability via the bus.

This makes the TJA1040 an excellent choice in nodes which can be in power-down or standby mode in partially powered networks.

## QUICK REFERENCE DATA

SYMBOL	PARAMETER	CONDITIONS	MIN.	MAX.	UNIT
$V_{CC}$	supply voltage	operating range	4.75	5.25	V
$I_{CC}$	supply current	standby mode	5	15	$\mu$ A
$V_{CANH}$	DC voltage on pin CANH	$0 < V_{CC} < 5.25$ V; no time limit	-27	+40	V
$V_{CANL}$	DC voltage on pin CANL	$0 < V_{CC} < 5.25$ V; no time limit	-27	+40	V
$V_{SPLIT}$	DC voltage on pin SPLIT	$0 < V_{CC} < 5.25$ V; no time limit	-27	+40	V
$V_{esd}$	electrostatic discharge voltage	Human Body Model (HBM) pins CANH, CANL and SPLIT all other pins	-6 -4	+6 +4	kV kV
$t_{PD(TXD-RXD)}$	propagation delay TXD to RXD	$V_{STB} = 0$ V	40	255	ns
$T_{vj}$	virtual junction temperature		-40	+150	$^{\circ}$ C

## ORDERING INFORMATION

TYPE NUMBER	PACKAGE		
	NAME	DESCRIPTION	VERSION
TJA1040T	SO8	plastic small outline package; 8 leads; body width 3.9 mm	SOT96-1
TJA1040U	-	bare die; die dimensions 1840 $\times$ 1440 $\times$ 380 $\mu$ m	-

# High speed CAN transceiver

# TJA1040

## BLOCK DIAGRAM

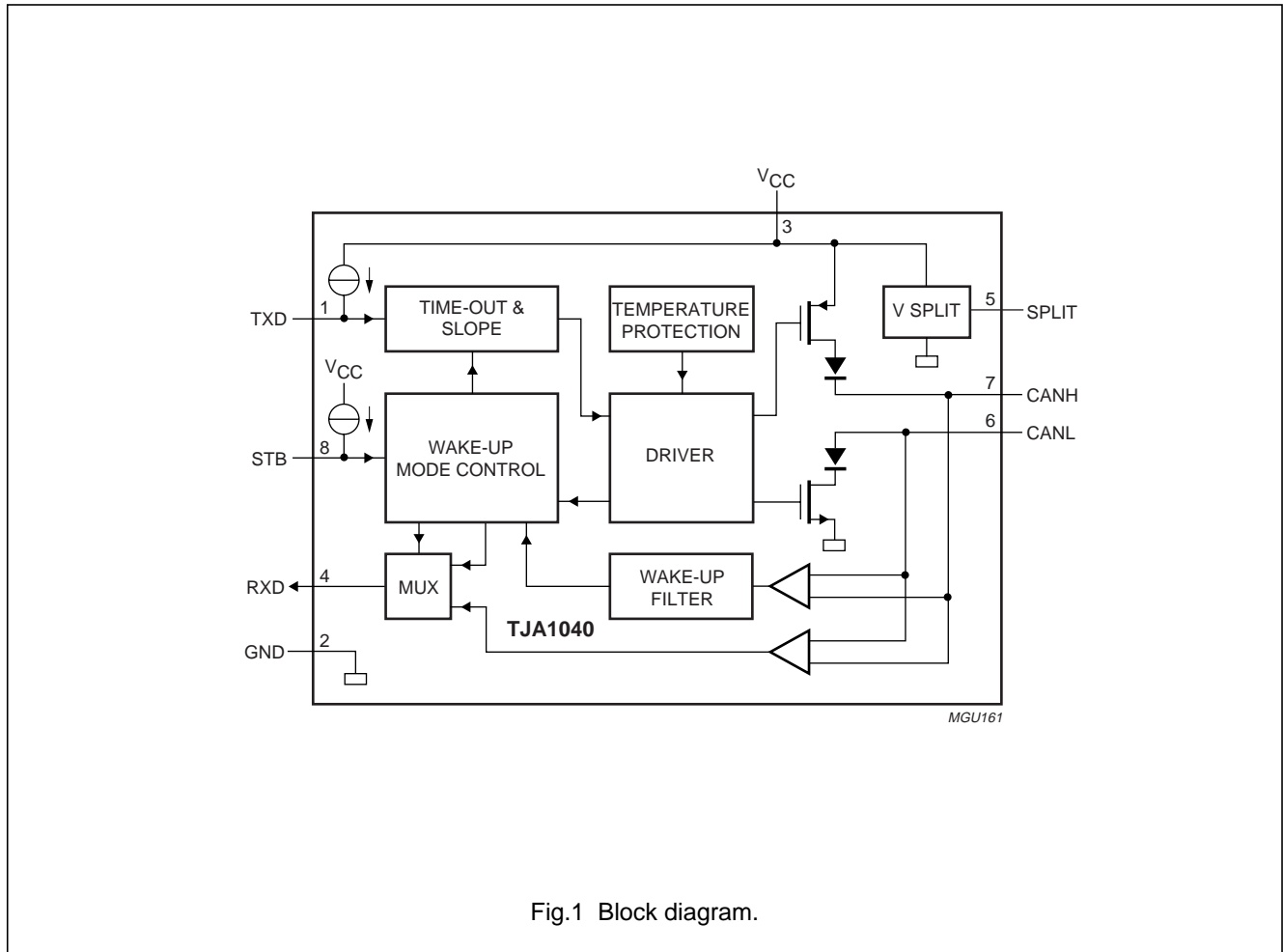

Fig.1 Block diagram.

## PINNING

SYMBOL	PIN	DESCRIPTION
TXD	1	transmit data input
GND	2	ground supply
V <sub>CC</sub>	3	supply voltage
RXD	4	receive data output; reads out data from the bus lines
SPLIT	5	common-mode stabilization output
CANL	6	LOW-level CAN bus line
CANH	7	HIGH-level CAN bus line
STB	8	standby mode control input

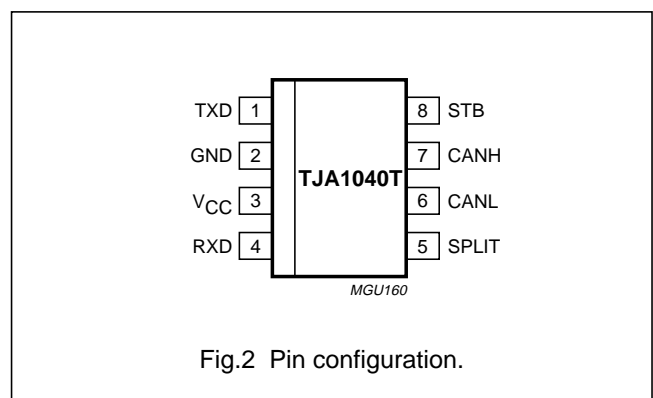

Fig.2 Pin configuration.

## High speed CAN transceiver

## TJA1040

**FUNCTIONAL DESCRIPTION****Operating modes**

The TJA1040 provides two modes of operation which are selectable via pin STB. See Table 1 for a description of the modes of operation.

**Table 1** Operating modes

MODE	PIN STB	PIN RXD	
		LOW	HIGH
normal	LOW	bus dominant	bus recessive
standby	HIGH	wake-up request detected	no wake-up request detected

**NORMAL MODE**

In this mode the transceiver is able to transmit and receive data via the bus lines CANH and CANL. See Fig.1 for the block diagram. The differential receiver converts the analog data on the bus lines into digital data which is output to pin RXD via the multiplexer (MUX). The slope of the output signals on the bus lines is fixed and optimized in a way that lowest ElectroMagnetic Emission (EME) is guaranteed.

**STANDBY MODE**

In this mode the transmitter and receiver are switched off, and the low-power differential receiver will monitor the bus lines. A HIGH level on pin STB activates this low-power receiver and the wake-up filter, and after  $t_{BUS}$  the state of the CAN bus is reflected on pin RXD.

The supply current on  $V_{CC}$  is reduced to a minimum in such a way that ElectroMagnetic Immunity (EMI) is guaranteed and a wake-up event on the bus lines will be recognized.

In this mode the bus lines are terminated to ground to reduce the supply current ( $I_{CC}$ ) to a minimum. A diode is added in series with the high-side driver of RXD to prevent a reverse current from RXD to  $V_{CC}$  in the unpowered state. In normal mode this diode is bypassed. This diode is not bypassed in standby mode to reduce current consumption.

**Split circuit**

Pin SPLIT provides a DC stabilized voltage of  $0.5V_{CC}$ . It is turned on only in normal mode. In standby mode pin SPLIT is floating. The  $V_{SPLIT}$  circuit can be used to stabilize the recessive common-mode voltage by connecting pin SPLIT

to the centre tap of the split termination (see Fig.4). In case of a recessive bus voltage  $<0.5V_{CC}$  due to the presence of an unpowered transceiver in the network with a significant leakage current from the bus lines to ground, the split circuit will stabilize this recessive voltage to  $0.5V_{CC}$ . So a start of transmission does not cause a step in the common-mode signal which would lead to poor ElectroMagnetic Emission (EME) behaviour.

**Wake-up**

In the standby mode the bus lines are monitored via a low-power differential comparator. Once the low-power differential comparator has detected a dominant bus level for more than  $t_{BUS}$ , pin RXD will become LOW.

**Over-temperature detection**

The output drivers are protected against over-temperature conditions. If the virtual junction temperature exceeds the shutdown junction temperature  $T_{j(sd)}$ , the output drivers will be disabled until the virtual junction temperature becomes lower than  $T_{j(sd)}$  and TXD becomes recessive again. By including the TXD condition, the occurrence of output driver oscillation due to temperature drifts is avoided.

**TXD dominant time-out function**

A 'TXD dominant time-out' timer circuit prevents the bus lines from being driven to a permanent dominant state (blocking all network communication) if pin TXD is forced permanently LOW by a hardware and/or software application failure. The timer is triggered by a negative edge on pin TXD.

If the duration of the LOW level on pin TXD exceeds the internal timer value ( $t_{dom}$ ), the transmitter is disabled, driving the bus lines into a recessive state. The timer is reset by a positive edge on pin TXD. The TXD dominant time-out time  $t_{dom}$  defines the minimum possible bit rate of 40 kBaud.

**Fail-safe features**

Pin TXD provides a pull-up towards  $V_{CC}$  in order to force a recessive level in case pin TXD is unpowered.

Pin STB provides a pull-up towards  $V_{CC}$  in order to force the transceiver into standby mode in case pin STB is unpowered.

In the event that the  $V_{CC}$  is lost, pins TXD, STB and RXD will become floating to prevent reverse supplying conditions via these pins.

## High speed CAN transceiver

TJA1040

**LIMITING VALUES**

In accordance with the Absolute Maximum Rating System (IEC 60134).

SYMBOL	PARAMETER	CONDITIONS	MIN.	MAX.	UNIT
V <sub>CC</sub>	supply voltage	no time limit	-0.3	+6	V
		operating range	4.75	5.25	V
V <sub>TXD</sub>	DC voltage on pin TXD		-0.3	V <sub>CC</sub> + 0.3	V
V <sub>RXD</sub>	DC voltage on pin RXD		-0.3	V <sub>CC</sub> + 0.3	V
V <sub>STB</sub>	DC voltage on pins STB		-0.3	V <sub>CC</sub> + 0.3	V
V <sub>CANH</sub>	DC voltage on pin CANH	0 < V <sub>CC</sub> < 5.25 V; no time limit	-27	+40	V
V <sub>CANL</sub>	DC voltage on pin CANL	0 < V <sub>CC</sub> < 5.25 V; no time limit	-27	+40	V
V <sub>SPLIT</sub>	DC voltage on pin SPLIT	0 < V <sub>CC</sub> < 5.25 V; no time limit	-27	+40	V
V <sub>trt</sub>	transient voltages on pins CANH, CANL and SPLIT	according to ISO 7637; see Fig.5	-200	+200	V
V <sub>esd</sub>	electrostatic discharge voltage	Human Body Model (HBM); note 1 pins CANH and CANL and SPLIT	-6	+6	kV
		all other pins	-4	+4	kV
		Machine Model (MM); note 2	-200	+200	V
T <sub>vj</sub>	virtual junction temperature	note 3	-40	+150	°C
T <sub>stg</sub>	storage temperature		-55	+150	°C

**Notes**

- Equivalent to discharging a 100 pF capacitor via a 1.5 kΩ series resistor.
- Equivalent to discharging a 200 pF capacitor via a 0.75 μH series inductor and a 10 Ω series resistor.
- Junction temperature in accordance with IEC 60747-1. An alternative definition of T<sub>vj</sub> is:  $T_{vj} = T_{amb} + P \times R_{th(vj-amb)}$ , where R<sub>th(vj-amb)</sub> is a fixed value to be used for the calculating of T<sub>vj</sub>. The rating for T<sub>vj</sub> limits the allowable combinations of power dissipation (P) and ambient temperature (T<sub>amb</sub>).

**THERMAL CHARACTERISTICS**

In accordance with IEC 60747-1.

SYMBOL	PARAMETER	CONDITIONS	VALUE	UNIT
R <sub>th(vj-a)</sub>	thermal resistance from virtual junction to ambient in SO8 package	in free air	145	K/W
R <sub>th(vj-s)</sub>	thermal resistance from virtual junction to substrate of bare die	in free air	50	K/W

**QUALITY SPECIFICATION**

Quality specification in accordance with "AEC-Q100".

## High speed CAN transceiver

TJA1040

**CHARACTERISTICS**

$V_{CC} = 4.75$  to  $5.25$  V,  $T_{vj} = -40$  to  $+150$  °C and  $R_L = 60$   $\Omega$  unless specified otherwise; all voltages are defined with respect to ground; positive currents flow into the IC; note 1.

SYMBOL	PARAMETER	CONDITIONS	MIN.	TYP.	MAX.	UNIT
<b>Supply (pin V<sub>CC</sub>)</b>						
I <sub>CC</sub>	supply current	standby mode	5	10	15	$\mu$ A
		normal mode				
		recessive; $V_{TXD} = V_{CC}$ dominant; $V_{TXD} = 0$ V	2.5 30	5 50	10 70	 mA mA
<b>Transmit data input (pin TXD)</b>						
V <sub>IH</sub>	HIGH-level input voltage		2	–	$V_{CC} + 0.3$	V
V <sub>IL</sub>	LOW-level input voltage		–0.3	–	+0.8	V
I <sub>IH</sub>	HIGH-level input current	$V_{TXD} = V_{CC}$	–5	0	+5	$\mu$ A
I <sub>IL</sub>	LOW-level input current	normal mode; $V_{TXD} = 0$ V	–100	–200	–300	$\mu$ A
C <sub>i</sub>	input capacitance	not tested	–	5	10	pF
<b>Standby mode control input (pin STB)</b>						
V <sub>IH</sub>	HIGH-level input voltage		2	–	$V_{CC} + 0.3$	V
V <sub>IL</sub>	LOW-level input voltage		–0.3	–	+0.8	V
I <sub>IH</sub>	HIGH-level input current	$V_{STB} = V_{CC}$	–	0	–	$\mu$ A
I <sub>IL</sub>	LOW-level input current	$V_{STB} = 0$ V	–1	–4	–10	$\mu$ A
<b>Receive data output (pin RXD)</b>						
V <sub>OH</sub>	HIGH-level output voltage	standby mode; $I_{RXD} = -100$ $\mu$ A	$V_{CC} - 1.1$	$V_{CC} - 0.7$	$V_{CC} - 0.4$	V
I <sub>OH</sub>	HIGH-level output current	normal mode; $V_{RXD} = V_{CC} - 0.4$ V	–0.1	–0.4	–1	mA
I <sub>OL</sub>	LOW-level output current	$V_{RXD} = 0.4$ V	2	6	12	mA
<b>Common-mode stabilization output (pin SPLIT)</b>						
V <sub>O</sub>	output voltage	normal mode; $-500$ $\mu$ A $< I_O < +500$ $\mu$ A	$0.3V_{CC}$	$0.5V_{CC}$	$0.7V_{CC}$	V
I <sub>L</sub>	leakage current	standby mode; $-22$ V $< V_{SPLIT} < +35$ V	–	0	5	$\mu$ A
<b>Bus lines (pins CANH and CANL)</b>						
V <sub>O(dom)</sub>	dominant output voltage	$V_{TXD} = 0$ V pin CANH	3	3.6	4.25	V
		pin CANL	0.5	1.4	1.75	V
V <sub>O(dom)(m)</sub>	matching of dominant output voltage ( $V_{CC} - V_{CANH} - V_{CANL}$ )		–100	0	+150	mV
V <sub>O(dif)(bus)</sub>	differential bus output voltage ( $V_{CANH} - V_{CANL}$ )	$V_{TXD} = 0$ V; dominant; $45$ $\Omega < R_L < 65$ $\Omega$	1.5	–	3.0	V
		$V_{TXD} = V_{CC}$ ; recessive; no load	–50	–	+50	mV

## High speed CAN transceiver

TJA1040

SYMBOL	PARAMETER	CONDITIONS	MIN.	TYP.	MAX.	UNIT
$V_{O(\text{reces})}$	recessive output voltage	normal mode; $V_{\text{TXD}} = V_{\text{CC}}$ ; no load	2	$0.5V_{\text{CC}}$	3	V
		standby mode; no load	-0.1	0	+0.1	V
$I_{O(\text{sc})}$	short-circuit output current	$V_{\text{TXD}} = 0 \text{ V}$ pin CANH; $V_{\text{CANH}} = 0 \text{ V}$	-40	-70	-95	mA
		pin CANL; $V_{\text{CANL}} = 40 \text{ V}$	40	70	100	mA
$I_{O(\text{reces})}$	recessive output current	$-27 \text{ V} < V_{\text{CAN}} < +32 \text{ V}$	-2.5	-	+2.5	mA
$V_{\text{dif}(\text{th})}$	differential receiver threshold voltage	$-12 \text{ V} < V_{\text{CANL}} < +12 \text{ V}$ ; $-12 \text{ V} < V_{\text{CANH}} < +12 \text{ V}$ normal mode (see Fig.6)	0.5	0.7	0.9	V
		standby mode	0.4	0.7	1.15	V
$V_{\text{hys}(\text{dif})}$	differential receiver hysteresis voltage	normal mode; $-12 \text{ V} < V_{\text{CANL}} < +12 \text{ V}$ ; $-12 \text{ V} < V_{\text{CANH}} < +12 \text{ V}$	50	70	100	mV
$I_{\text{LI}}$	input leakage current	$V_{\text{CC}} = 0 \text{ V}$ ; $V_{\text{CANH}} = V_{\text{CANL}} = 5 \text{ V}$	-5	0	+5	$\mu\text{A}$
$R_{i(\text{cm})}$	common-mode input resistance	standby or normal mode	15	25	35	$\text{k}\Omega$
$R_{i(\text{cm})(\text{m})}$	common-mode input resistance matching	$V_{\text{CANH}} = V_{\text{CANL}}$	-3	0	+3	%
$R_{i(\text{dif})}$	differential input resistance	standby or normal mode	25	50	75	$\text{k}\Omega$
$C_{i(\text{cm})}$	common-mode input capacitance	$V_{\text{TXD}} = V_{\text{CC}}$ ; not tested	-	-	20	pF
$C_{i(\text{dif})}$	differential input capacitance	$V_{\text{TXD}} = V_{\text{CC}}$ ; not tested	-	-	10	pF
<b>Timing characteristics; see Fig.8</b>						
$t_{\text{d}(\text{TXD-BUSon})}$	delay TXD to bus active	normal mode	25	70	110	ns
$t_{\text{d}(\text{TXD-BUSoff})}$	delay TXD to bus inactive		10	50	95	ns
$t_{\text{d}(\text{BUSon-RXD})}$	delay bus active to RXD		15	65	115	ns
$t_{\text{d}(\text{BUSoff-RXD})}$	delay bus inactive to RXD		35	100	160	ns
$t_{\text{PD}(\text{TXD-RXD})}$	propagation delay TXD to RXD	$V_{\text{STB}} = 0 \text{ V}$	40	-	255	ns
$t_{\text{dom}(\text{TXD})}$	TXD dominant time-out	$V_{\text{TXD}} = 0 \text{ V}$	300	600	1000	$\mu\text{s}$
$t_{\text{BUS}}$	dominant time for wake-up via bus	standby mode	0.75	1.75	5	$\mu\text{s}$
$t_{\text{d}(\text{stb-norm})}$	delay standby mode to normal mode	normal mode	5	7.5	10	$\mu\text{s}$
<b>Thermal shutdown</b>						
$T_{\text{j}(\text{sd})}$	shutdown junction temperature		155	165	180	$^{\circ}\text{C}$

**Note**

1. All parameters are guaranteed over the virtual junction temperature range by design, but only 100% tested at 125 °C ambient temperature for dies on wafer level, and in addition to this 100% tested at 25 °C ambient temperature for cased products; unless specified otherwise. For bare dies, all parameters are only guaranteed with the backside of the die connected to ground.

# High speed CAN transceiver

# TJA1040

## APPLICATION AND TEST INFORMATION

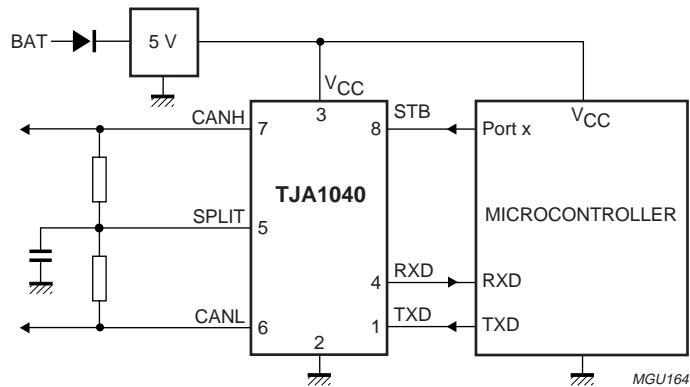

More application information is available in a separate application note.

Fig.3 Typical application for 5 V microcontroller.

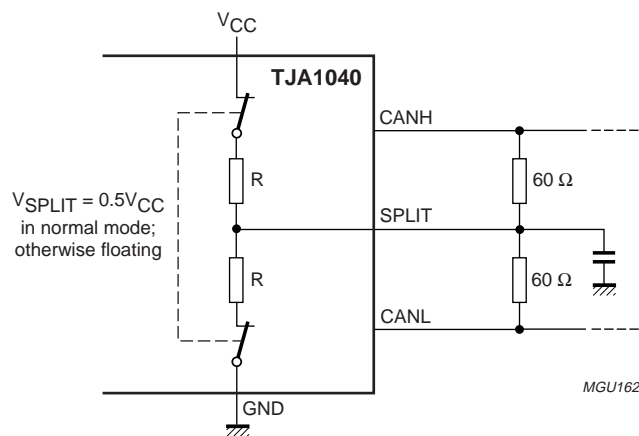
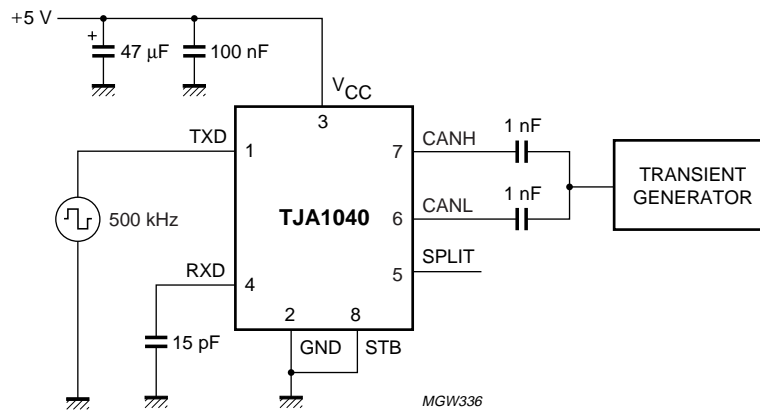

Fig.4 Stabilization circuitry and application.



High speed CAN transceiver

TJA1040



The waveforms of the applied transients will be in accordance with ISO 7637 part 1, test pulses 1, 2, 3a, 3b, 5, 6 and 7.

Fig.5 Test circuit for automotive transients.

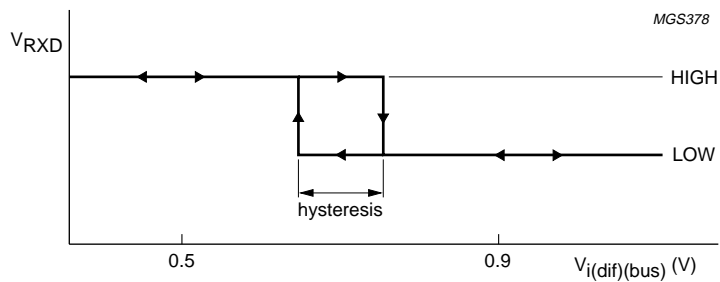

Fig.6 Hysteresis of the receiver.

High speed CAN transceiver

TJA1040

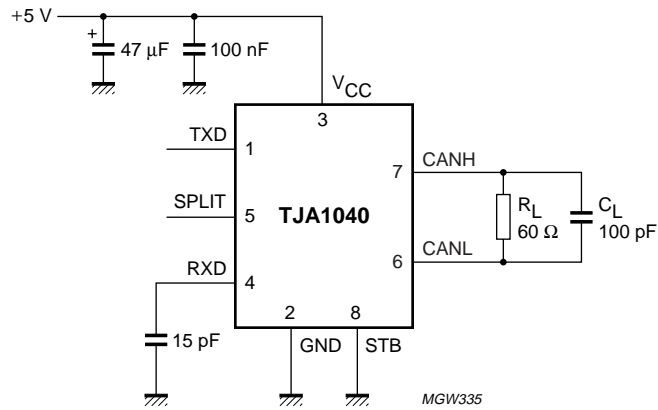
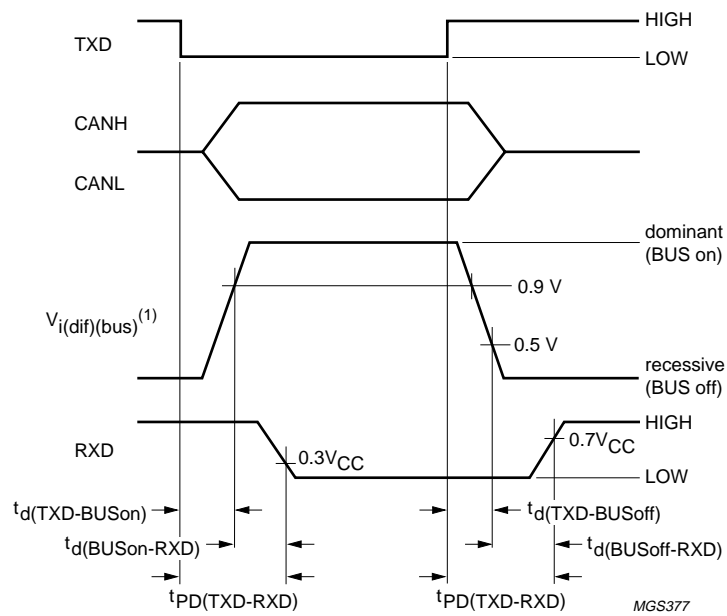

Fig.7 Test circuit for timing characteristics.



(1)  $V_{i(dif)(bus)} = V_{CANH} - V_{CANL}$ .

Fig.8 Timing diagram.

# High speed CAN transceiver

# TJA1040

## BONDING PAD LOCATIONS

SYMBOL	PAD	COORDINATES <sup>(1)</sup>	
		x	y
TXD	1	119.5	114.5
GND	2	648.5	85
V <sub>CC</sub>	3	1214.25	114.5
RXD	4	1635.25	114.5
SPLIT	5	1516.5	1275
CANL	6	990.5	1273.75
CANH	7	530.25	1273.75
STB	8	113.75	1246

### Note

1. All x/y coordinates represent the position of the centre of each pad (in  $\mu\text{m}$ ) with respect to the left hand bottom corner of the top aluminium layer (see Fig.9).

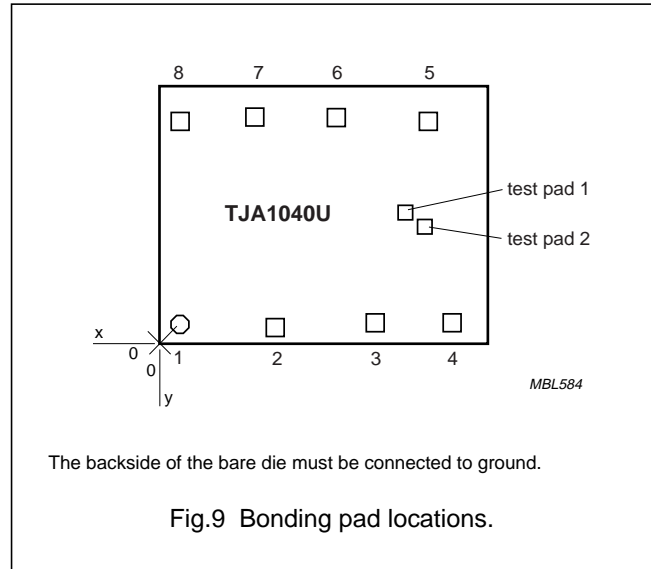

High speed CAN transceiver

TJA1040

PACKAGE OUTLINE

SO8: plastic small outline package; 8 leads; body width 3.9 mm

SOT96-1

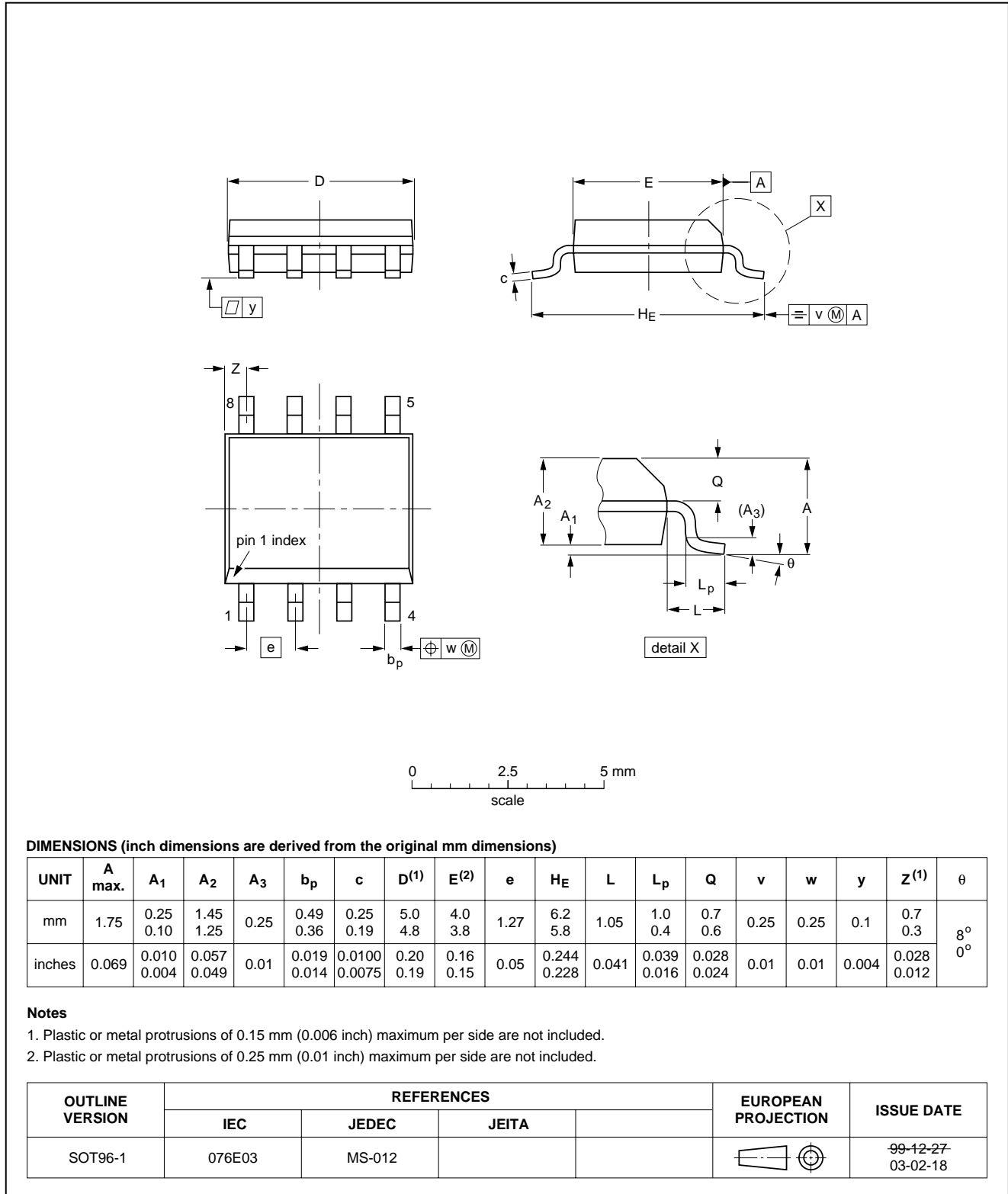

## High speed CAN transceiver

TJA1040

### SOLDERING

#### Introduction to soldering surface mount packages

This text gives a very brief insight to a complex technology. A more in-depth account of soldering ICs can be found in our *"Data Handbook IC26; Integrated Circuit Packages"* (document order number 9398 652 90011).

There is no soldering method that is ideal for all surface mount IC packages. Wave soldering can still be used for certain surface mount ICs, but it is not suitable for fine pitch SMDs. In these situations reflow soldering is recommended.

#### Reflow soldering

Reflow soldering requires solder paste (a suspension of fine solder particles, flux and binding agent) to be applied to the printed-circuit board by screen printing, stencilling or pressure-syringe dispensing before package placement. Driven by legislation and environmental forces the worldwide use of lead-free solder pastes is increasing.

Several methods exist for reflowing; for example, convection or convection/infrared heating in a conveyor type oven. Throughput times (preheating, soldering and cooling) vary between 100 and 200 seconds depending on heating method.

Typical reflow peak temperatures range from 215 to 270 °C depending on solder paste material. The top-surface temperature of the packages should preferably be kept:

- below 220 °C (SnPb process) or below 245 °C (Pb-free process)
  - for all BGA and SSOP-T packages
  - for packages with a thickness  $\geq 2.5$  mm
  - for packages with a thickness  $< 2.5$  mm and a volume  $\geq 350$  mm<sup>3</sup> so called thick/large packages.
- below 235 °C (SnPb process) or below 260 °C (Pb-free process) for packages with a thickness  $< 2.5$  mm and a volume  $< 350$  mm<sup>3</sup> so called small/thin packages.

Moisture sensitivity precautions, as indicated on packing, must be respected at all times.

#### Wave soldering

Conventional single wave soldering is not recommended for surface mount devices (SMDs) or printed-circuit boards with a high component density, as solder bridging and non-wetting can present major problems.

To overcome these problems the double-wave soldering method was specifically developed.

If wave soldering is used the following conditions must be observed for optimal results:

- Use a double-wave soldering method comprising a turbulent wave with high upward pressure followed by a smooth laminar wave.
- For packages with leads on two sides and a pitch (e):
  - larger than or equal to 1.27 mm, the footprint longitudinal axis is **preferred** to be parallel to the transport direction of the printed-circuit board;
  - smaller than 1.27 mm, the footprint longitudinal axis **must** be parallel to the transport direction of the printed-circuit board.

The footprint must incorporate solder thieves at the downstream end.

- For packages with leads on four sides, the footprint must be placed at a 45° angle to the transport direction of the printed-circuit board. The footprint must incorporate solder thieves downstream and at the side corners.

During placement and before soldering, the package must be fixed with a droplet of adhesive. The adhesive can be applied by screen printing, pin transfer or syringe dispensing. The package can be soldered after the adhesive is cured.

Typical dwell time of the leads in the wave ranges from 3 to 4 seconds at 250 °C or 265 °C, depending on solder material applied, SnPb or Pb-free respectively.

A mildly-activated flux will eliminate the need for removal of corrosive residues in most applications.

#### Manual soldering

Fix the component by first soldering two diagonally-opposite end leads. Use a low voltage (24 V or less) soldering iron applied to the flat part of the lead. Contact time must be limited to 10 seconds at up to 300 °C.

When using a dedicated tool, all other leads can be soldered in one operation within 2 to 5 seconds between 270 and 320 °C.

## High speed CAN transceiver

TJA1040

## Suitability of surface mount IC packages for wave and reflow soldering methods

PACKAGE <sup>(1)</sup>	SOLDERING METHOD	
	WAVE	REFLOW <sup>(2)</sup>
BGA, LBGA, LFBGA, SQFP, SSOP-T <sup>(3)</sup> , TFBGA, VFBGA	not suitable	suitable
DHVQFN, HBCC, HBGA, HLQFP, HSQFP, HSOP, HTQFP, HTSSOP, HVQFN, HVSON, SMS	not suitable <sup>(4)</sup>	suitable
PLCC <sup>(5)</sup> , SO, SOJ	suitable	suitable
LQFP, QFP, TQFP	not recommended <sup>(5)(6)</sup>	suitable
SSOP, TSSOP, VSO, VSSOP	not recommended <sup>(7)</sup>	suitable
PMFP <sup>(8)</sup>	not suitable	not suitable

## Notes

- For more detailed information on the BGA packages refer to the “(LF)BGA Application Note” (AN01026); order a copy from your Philips Semiconductors sales office.
- All surface mount (SMD) packages are moisture sensitive. Depending upon the moisture content, the maximum temperature (with respect to time) and body size of the package, there is a risk that internal or external package cracks may occur due to vaporization of the moisture in them (the so called popcorn effect). For details, refer to the Drypack information in the “Data Handbook IC26; Integrated Circuit Packages; Section: Packing Methods”.
- These transparent plastic packages are extremely sensitive to reflow soldering conditions and must on no account be processed through more than one soldering cycle or subjected to infrared reflow soldering with peak temperature exceeding  $217\text{ °C} \pm 10\text{ °C}$  measured in the atmosphere of the reflow oven. The package body peak temperature must be kept as low as possible.
- These packages are not suitable for wave soldering. On versions with the heatsink on the bottom side, the solder cannot penetrate between the printed-circuit board and the heatsink. On versions with the heatsink on the top side, the solder might be deposited on the heatsink surface.
- If wave soldering is considered, then the package must be placed at a  $45^\circ$  angle to the solder wave direction. The package footprint must incorporate solder thieves downstream and at the side corners.
- Wave soldering is suitable for LQFP, TQFP and QFP packages with a pitch (e) larger than 0.8 mm; it is definitely not suitable for packages with a pitch (e) equal to or smaller than 0.65 mm.
- Wave soldering is suitable for SSOP, TSSOP, VSO and VSSOP packages with a pitch (e) equal to or larger than 0.65 mm; it is definitely not suitable for packages with a pitch (e) equal to or smaller than 0.5 mm.
- Hot bar or manual soldering is suitable for PMFP packages.

## REVISION HISTORY

REV	DATE	CPCN	DESCRIPTION
6	20031014	200307014	<b>Product specification (9397 750 11837)</b> Modification: <ul style="list-style-type: none"> <li>Change ‘<math>V_{th(dif)} = 0.5\text{ V}</math>’ in standby mode into ‘<math>V_{dif(th)} = 0.4\text{ V}</math>’</li> <li>Add Chapter REVISION HISTORY</li> </ul>
5	20030219	–	<b>Product specification (9397 750 10887)</b>

## High speed CAN transceiver

TJA1040

## DATA SHEET STATUS

LEVEL	DATA SHEET STATUS <sup>(1)</sup>	PRODUCT STATUS <sup>(2)(3)</sup>	DEFINITION
I	Objective data	Development	This data sheet contains data from the objective specification for product development. Philips Semiconductors reserves the right to change the specification in any manner without notice.
II	Preliminary data	Qualification	This data sheet contains data from the preliminary specification. Supplementary data will be published at a later date. Philips Semiconductors reserves the right to change the specification without notice, in order to improve the design and supply the best possible product.
III	Product data	Production	This data sheet contains data from the product specification. Philips Semiconductors reserves the right to make changes at any time in order to improve the design, manufacturing and supply. Relevant changes will be communicated via a Customer Product/Process Change Notification (CPCN).

## Notes

1. Please consult the most recently issued data sheet before initiating or completing a design.
2. The product status of the device(s) described in this data sheet may have changed since this data sheet was published. The latest information is available on the Internet at URL <http://www.semiconductors.philips.com>.
3. For data sheets describing multiple type numbers, the highest-level product status determines the data sheet status.

## DEFINITIONS

**Short-form specification** — The data in a short-form specification is extracted from a full data sheet with the same type number and title. For detailed information see the relevant data sheet or data handbook.

**Limiting values definition** — Limiting values given are in accordance with the Absolute Maximum Rating System (IEC 60134). Stress above one or more of the limiting values may cause permanent damage to the device. These are stress ratings only and operation of the device at these or at any other conditions above those given in the Characteristics sections of the specification is not implied. Exposure to limiting values for extended periods may affect device reliability.

**Application information** — Applications that are described herein for any of these products are for illustrative purposes only. Philips Semiconductors make no representation or warranty that such applications will be suitable for the specified use without further testing or modification.

## DISCLAIMERS

**Life support applications** — These products are not designed for use in life support appliances, devices, or systems where malfunction of these products can reasonably be expected to result in personal injury. Philips Semiconductors customers using or selling these products for use in such applications do so at their own risk and agree to fully indemnify Philips Semiconductors for any damages resulting from such application.

**Right to make changes** — Philips Semiconductors reserves the right to make changes in the products - including circuits, standard cells, and/or software - described or contained herein in order to improve design and/or performance. When the product is in full production (status 'Production'), relevant changes will be communicated via a Customer Product/Process Change Notification (CPCN). Philips Semiconductors assumes no responsibility or liability for the use of any of these products, conveys no licence or title under any patent, copyright, or mask work right to these products, and makes no representations or warranties that these products are free from patent, copyright, or mask work right infringement, unless otherwise specified.

---

## High speed CAN transceiver

TJA1040

---

**Bare die** — All die are tested and are guaranteed to comply with all data sheet limits up to the point of wafer sawing for a period of ninety (90) days from the date of Philips' delivery. If there are data sheet limits not guaranteed, these will be separately indicated in the data sheet. There are no post packing tests performed on individual die or wafer. Philips Semiconductors has no control of third party procedures in the sawing, handling, packing or assembly of the die. Accordingly, Philips Semiconductors assumes no liability for device functionality or performance of the die or systems after third party sawing, handling, packing or assembly of the die. It is the responsibility of the customer to test and qualify their application in which the die is used.



# ***Philips Semiconductors – a worldwide company***

## **Contact information**

For additional information please visit <http://www.semiconductors.philips.com>. Fax: +31 40 27 24825

For sales offices addresses send e-mail to: [sales.addresses@www.semiconductors.philips.com](mailto:sales.addresses@www.semiconductors.philips.com).

© Koninklijke Philips Electronics N.V. 2003

SCA75

All rights are reserved. Reproduction in whole or in part is prohibited without the prior written consent of the copyright owner.

The information presented in this document does not form part of any quotation or contract, is believed to be accurate and reliable and may be changed without notice. No liability will be accepted by the publisher for any consequence of its use. Publication thereof does not convey nor imply any license under patent- or other industrial or intellectual property rights.

Printed in The Netherlands

R16/06/pp17

Date of release: 2003 Oct 14

Document order number: 9397 750 11837

*Let's make things better.*

**Philips  
Semiconductors**



**PHILIPS**